

## SERVING UP A RULE CHANGE FOR DOUBLES

Wendell Dillon, Chair of USATT Officials Committee  
Marilyn Sommer Feinstein, USPTA

- What if there were a way to level the playing field when lefties and righties play each other in doubles?
- What if your doubles team had more tactics in your arsenal?
- What if there were an easier way to stay on track and not get mixed up with the score in doubles?

In singles, you, the player, are not relegated to having to serve only from the right side. There is a greater array of angles you may use by having both diagonals from which to choose (as well as the option of serving from the middle). Why shouldn't servers in doubles be given a greater array of angles (that they would automatically have by serving one serve from the right and the 2<sup>nd</sup> serve from the left side)?

Over the years, the idea of serving from alternate sides in doubles has been discussed, but was not conducive with the former scoring rules of *5 serves at a time*. Now, with the already established rule change of alternating with *2 serves per set of serves*, the idea of alternating diagonals when serving (from the right and left sides) now makes sense.

The USATT wishes to BETA TEST this rule change. We are inviting you to try out the following serving format for doubles at your respective clubs and provide us with written feedback with the survey at end of article:

- **The server shall serve the 1<sup>st</sup> serve from the right side of the table and the 2<sup>nd</sup> serve from the left side**
- **As the receiver follows the same person throughout the particular game of the match, the server shall serve the 1<sup>st</sup> serve from the right side of the table, and the 2<sup>nd</sup> serve to the *same* receiver from the left side**
- **Should the game go to deuce, each server continues to serve from the right side of the table (*or should it be the server's choice?*)**

As shown in the following diagram, player X of the XY team serves his or her first serve to player A of the AB team and the 4 players play out the point; player X then serves his or her second serve again to player A (as in current doubles rules, player A always follows player X in the current game), but from the left side of the table. Play continues with each server serving their 1<sup>st</sup> of 2 serves from their right side of the table; and their 2<sup>nd</sup> of 2 serves from their left side of the table to the same receiver each time.

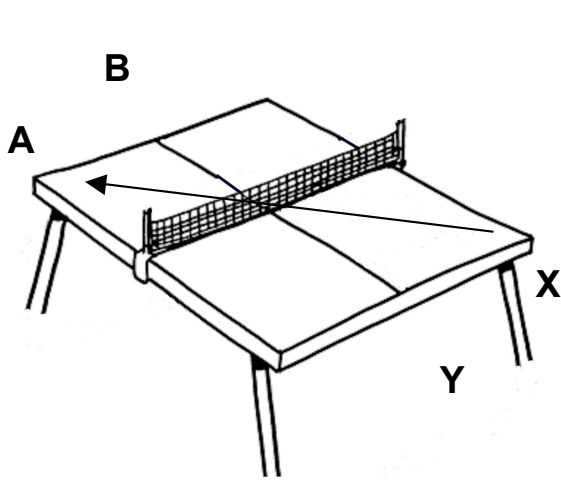

**Fig. 1.**  
1st of 2 Serves:  
X serves to A from Right Side

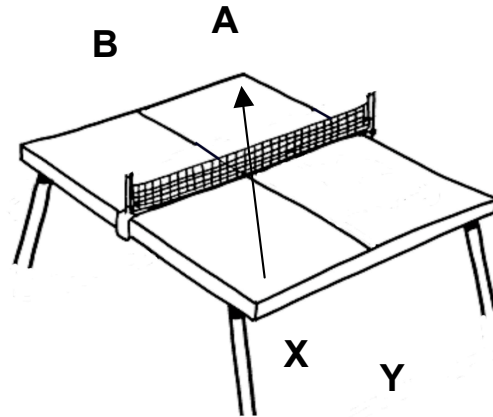

**Fig. 2.**  
2nd of 2 Serves:  
X serves to A from Left Side

This modification of serving in doubles could not only level the playing field for lefties and righties, but could actually build more creativity into the playing dynamics of the match. The larger array of angles built into serving from the left side of the table as well as from the right side could add another dimension to the game. Who knows, maybe this added dimension could help make doubles more fun to play and more interesting for others to watch.

We are interested in having you play some matches with the proposed rule change. Below you'll find a survey to fill out and return *after* playing with the new format.